

Gusmer Enterprises offers a complete line of Cellu-Stack housings designed as a cost effective system for high capacity liquid filtration applications. The versatile housing line is offered in Industrial, Sanitary Style Industrial, and Sanitary models to accommodate either 12" or 16" diameter Cellu-Stack filter modules. All housings are available in 1, 2, 3, or 4 stack versions which can be modified with the use of Cellu-Stack take-up adapters to accept fewer stacks for partial batch runs or other applications requiring fewer stacks. ASME code housings are also available if required.

Typical Applications

- ▶ Cosmetics
- ▶ Decolorization
- ▶ Electroplating Solutions
- ▶ Enzymes
- ▶ Fine Chemical Purification
- ▶ Flavor and Fragrances
- ▶ Food and Beverage
- ▶ Food and Beverage
- ▶ Photographic Solutions
- ▶ Printing Inks

Design Features

- ◆ All wetted surfaces are ³¹⁶L Stainless Steel.
- ◆ Unique removable center post assembly retained by exterior bolts.
- ◆ Center post guide rods are welded to perimeter of outlet port. No threaded parts are exposed to the product being filtered.
- ◆ Vent valve and gauge assembly is removable from housing dome to facilitate easy and thorough cleaning.
- ◆ Maximum operating pressure: 125 psi @ 250°F (8.79 Kgf/cm² @ 121°C).



Benefits

- ◆ Eye bolt clamping system for fast stack change-outs and secure dome closure.
- ◆ Removable center post assembly for quick and thorough cleaning.
- ◆ Base plate design minimizes product hold-up volume and facilitates thorough cleaning.
- ◆ Adapters are available to allow operation with fewer stacks for partial batch runs.
- ◆ Spring assisted follower tube maintains a positive stack seal.
- ◆ Compact design requires minimal floor space.
- ◆ Units can be skid mounted for mobility.

External Finish	
Industrial	Beadblast & passivated
Sanitary Style Industrial	Passivated and electropolished, ³⁵ Ra
Sanitary	Passivated and electropolished, ²⁵ Ra, Welds ground
Interior Finish	
Industrial	Beadblast & passivated
Sanitary Style Industrial	Passivated and electropolished, ²⁵ Ra
Sanitary	Passivated and electropolished, ²⁰ Ra, Welds ground

Housing Specifications

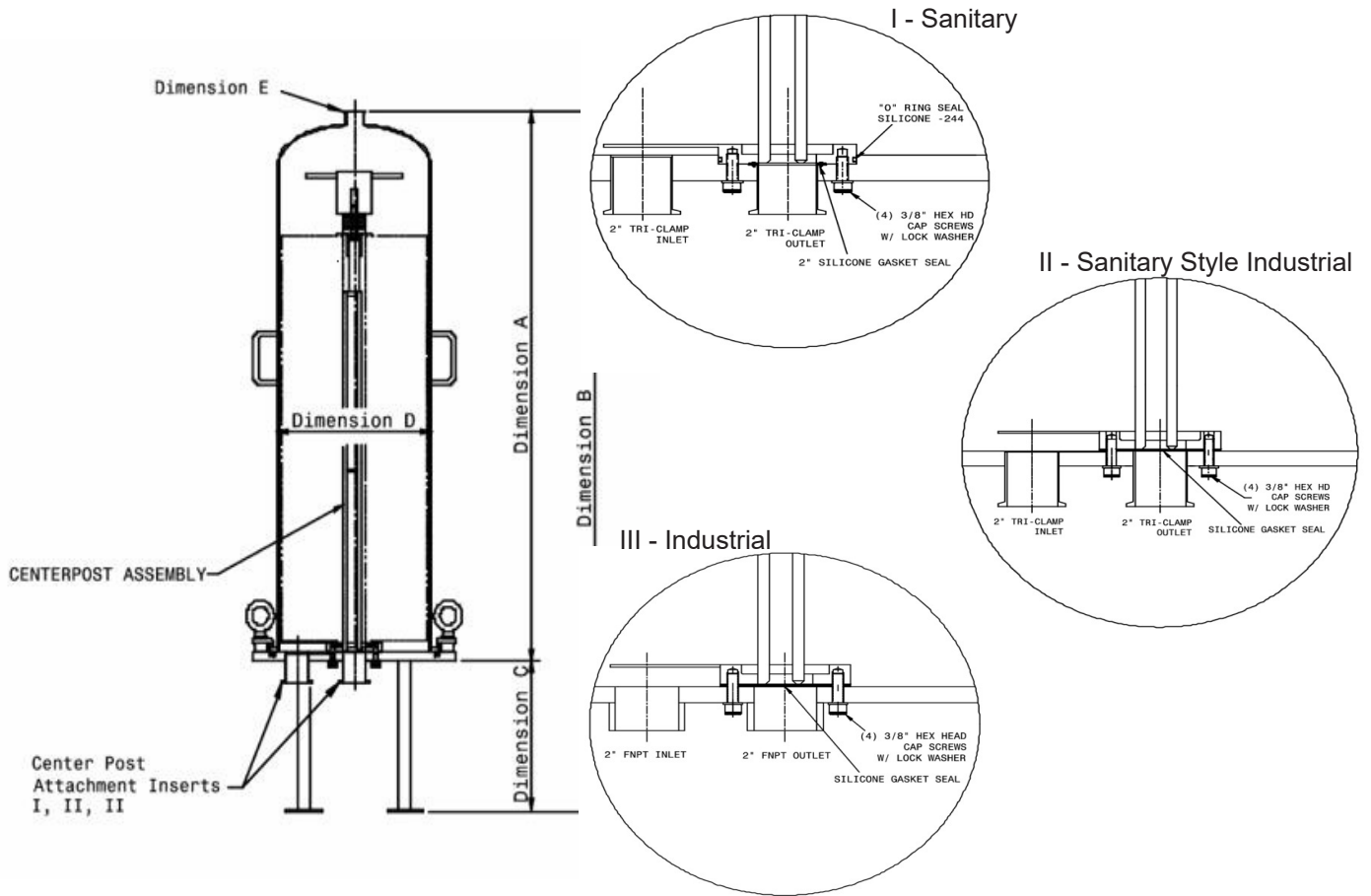

Dimensions (inches)

Housing Style	A				B				C	D	E
	1-HIGH	2-HIGH	3-HIGH	4-HIGH	1-HIGH	2-HIGH	3-HIGH	4-HIGH			
IN-12	22.00	32.00	42.00	52.00	33.50	43.50	53.50	63.50	11.50	12.75	.25 FNPT
SI-12	22.00	32.00	42.00	52.00	33.50	43.50	53.50	63.50	11.50	12.75	1.5 TRI-CLAMP
SA-12	22.00	32.00	42.00	52.00	33.50	43.50	53.50	63.50	11.50	12.75	1.5 TRI-CLAMP
IN-16	21.00	31.00	41.00	51.00	32.50	42.50	52.50	62.50	11.50	18.00	.25 FNPT
SI-16	21.75	31.75	41.75	51.75	33.25	43.25	53.25	63.25	11.50	18.00	1.5 TRI-CLAMP
SA-16	22.00	32.00	42.00	52.00	33.50	43.50	53.50	63.50	11.50	18.00	1.5 TRI-CLAMP

IN - Industrial
SI - Sanitary Style Industrial
SA - Sanitary (welds ground)

Weights and Volumes

Housing Style	Dome Weight (lbs)				Approximate Liquid Capacity ¹ (gal)				Approximate Shipping Weight (lbs)			
	1-HIGH	2-HIGH	3-HIGH	4-HIGH	1-HIGH	2-HIGH	3-HIGH	4-HIGH	1-HIGH	2-HIGH	3-HIGH	4-HIGH
IN-12	30	38	46	54	8.3	13.5	18.8	24.0	112	120	128	136
SI-12	30	38	46	54	8.3	13.5	18.8	24.0	112	120	128	136
SA-12	35	43	51	59	8.3	13.5	18.8	24.0	130	138	146	154
IN-16	47	60	73	86	14.5	25.3	36.0	46.8	272	285	298	311
SI-16	47	60	73	86	14.5	25.3	36.0	46.8	272	285	298	311
SA-16	54	71	88	105	14.5	25.3	36.0	46.8	304	321	338	355

¹Liquid capacities based on a full compliment of Cellu-Stacks loaded into housing.

Stack Adapters

The Gusmer Enterprises housing line is capable of utilizing less than the full compliment of Cellu-Stacks® when necessary. This can easily be accomplished with optional stack adapters available in various configurations. Standard adapters are constructed of Delrin® and include nitrile gaskets. Optional adapter materials include polypropylene or nylon and various gasket materials as listed under the Housing Ordering Guide. The following selection guide provides the appropriate adapter(s) needed to accommodate less than the full series of modules in the specified housing versions.

Stack Adapter	A	B	C
Part Number	A ¹⁰⁸⁸	A ⁰⁶⁵⁰	A ⁰²⁶³
Item Description	10 88"	6 50"	2 63"

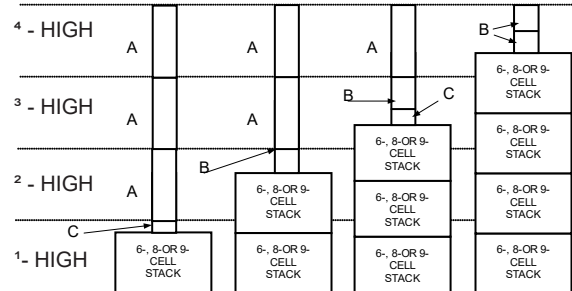
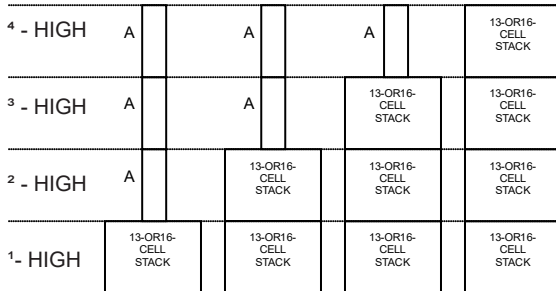

Adapter combinations are the same for the 13" and 16" or 6", 8" and 9" cell stacks regardless of dome height or housing style.

Housing Operation

Illustrated is the flow path of product being filtered through a Cellu-Stack®. The unfiltered product is pumped in through the base plate inlet port. The Cellu-Stacks® are protected from flow impingement by the diffusion plate. The liquid floods the housing and flows through each cell of the filter media in parallel sequence into the center of the stack and exits through the outlet port.

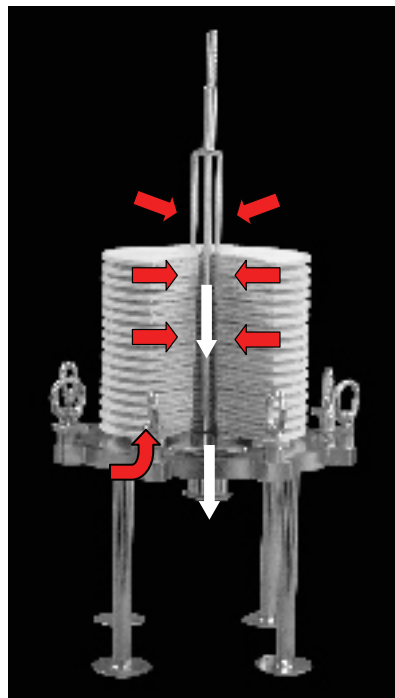

Cellu-Stack® Housing Order Guide

XX-XXX-XXXXXX

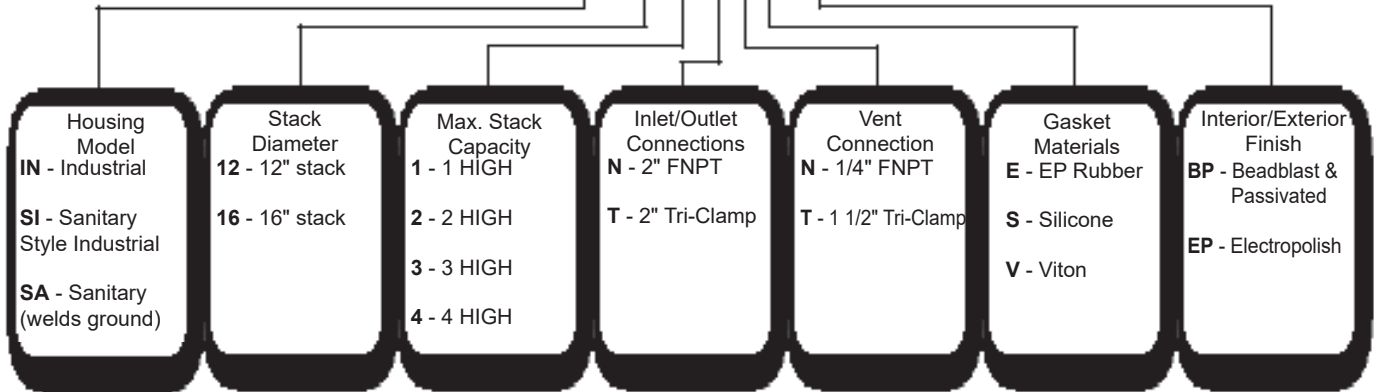

Example: To order a standard 12" 1-HIGH Industrial housing with standard connections, gaskets, and surface finish, the order should read as follows: IN-121-NNEBP

SPARE PARTS LIST

Center Post	¹ -HIGH	² -HIGH	³ -HIGH	⁴ -HIGH	
Industrial	INCP- ¹ H	INCP- ² H	INCP- ³ H	INCP- ⁴ H	Beadblast and passivated finish; includes gasket and bolts
Sanitary Style Industrial	INCP- ¹ H-EP	INCP- ² H-EP	INCP- ³ H-EP	INCP- ⁴ H-EP	Electropolished finish; includes gasket and bolts
Sanitary	SACP- ¹ H	SACP- ² H	SACP- ³ H	SACP- ⁴ H	Electropolished finish; includes gasket, o-ring and bolts

Seal Kit	Industrial		Sanitary	
	12"	16"	12"	16"
Silicone	¹² -INSK-S	¹⁶ -INSK-S	¹² -SASK-S	¹⁶ -SASK-S
EPDM	¹² -INSK-E	¹⁶ -INSK-E	¹² -SASK-E	¹⁶ -SASK-E
Viton	¹² -INSK-V	¹⁶ -INSK-V	¹² -SASK-V	¹⁶ -SASK-V

Kit includes all replacement o-rings, gaskets, retainer bolts and washers.

Follower Tube Assembly	Part Designation
Complete Follower Assembly (contains next 4 items)	FNSLA ⁰⁰¹
Filter nut - Delrin®	FNSL ⁰⁰¹
Follower tube - Delrin® w/silicone o-ring	FOL ⁰⁰¹
Follower tube spring - electropolished	SP ⁰⁰¹
Filter nut rod	FNR ⁰⁰¹

Pressure Gauge & Vent Assembly	Part Designation
Industrial	IN-VENT-ASSY
Sanitary Style Industrial	SA-VENT-ASSY
Sanitary	SA-VENT-ASSY



Important Note: Gusmer Enterprises, Inc. provides this information to the best of our knowledge. This information does not claim to be complete and Gusmer Enterprises, Inc. cannot assume liability for improper use. All users are advised to test products to meet their specific needs.