

IN LINE GAS INJECTOR

Air, O₂, CO₂, N₂

- Micro bubble size
- Instant saturation
- No gas and flavour loss
- Efficient, hygienic design
- Maintenance free



I N L I N E G A S I N J E C T O R

Principle

The DENWEL Injector splits the gas into micro bubbles. Individually designed for each application, it combines turbulent flow and increased pressure for an optimal mass transfer rate from gas to liquid.

Most efficient and instant dissolution of gas is achieved with only minimal pressure drop and no gas and flavour loss. No static mixer, sinter candle or recirculation tank is required. Designed for CIP, no parts of the Injector have to be removed for sanitation.

Technical data

Aeration:	up to 15 mg/l
Oxygenation:	up to 50 mg/l
Carbonation:	up to 6 g/l
Nitrogenation:	up to 20 ppm
Pressure:	operating 3 to 5 barg, 30 to 72 psig
Temperature:	operating 0 to 12 °C, 32 to 55 °F
CIP:	3 to 5 barg, 30 to 72 psig; max. 90 °C, 200 °F
Connection:	Tri-clamp; other connections upon request
Material:	Stainless Steel 304
Models:	DGIxxxA for Air, DGIxxxO for O ₂ , DGIxxxC for CO ₂ ; DGIxxxN for N ₂

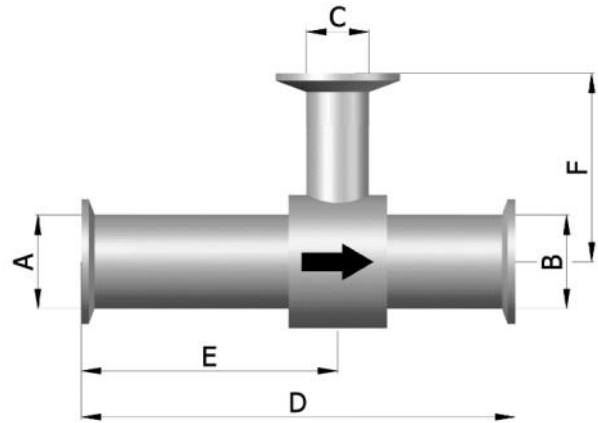

DGI025_	DN 25	1"	10 to 25 hl/h	5 to 11 gpm	9 to 21 bbls/h
DGI040_	DN 40	1½"	16 to 40 hl/h	8 to 17 gpm	14 to 34 bbls/h
DGI050_	DN 40	1½"	20 to 50 hl/h	9 to 22 gpm	18 to 42 bbls/h
DGI075_	DN 40	1½"	30 to 75 hl/h	14 to 33 gpm	26 to 63 bbls/h
DGI100_	DN 50	2"	40 to 100 hl/h	18 to 44 gpm	35 to 85 bbls/h
DGI150_	DN 65	2½"	60 to 150 hl/h	27 to 66 gpm	52 to 127 bbls/h
DGI200_	DN 65	2½"	80 to 200 hl/h	36 to 88 gpm	69 to 170 bbls/h
DGI300_	DN 80	3"	120 to 300 hl/h	53 to 132 gpm	103 to 225 bbls/h
DGI500_	DN 100	4"	200 to 500 hl/h	88 to 220 gpm	171 to 426 bbls/h
DGI750_	DN 125	5"	300 to 750 hl/h	132 to 330 gpm	256 to 639 bbls/h
DGIA00_	DN 150	6"	400 to 1000 hl/h	176 to 440 gpm	341 to 852 bbls/h