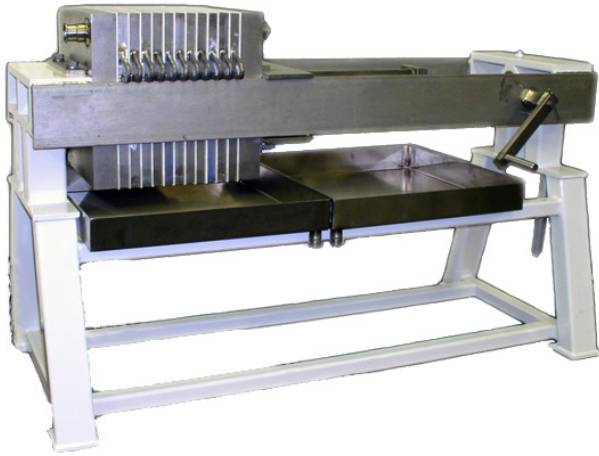



Plate & Frame Filter Press



Gusmer Enterprises offers state of the art Plate & Frame Filter Presses in 17" and 25" square frame sizes. The versatility of the unit allows customized modifications to be made fulfilling all specific filtration application requirements. The precision designed unit consists of a rugged carbon steel frame coated in durable epoxy paint. All wetted contact parts and side rails are fabricated from solid bars, plates and forgings of 304 stainless steel. The internally ported design provides a positive seal when using filter media of various types and thicknesses resulting in near-zero leakage without a need for gaskets. Personalized requests such as: special alloys of construction, desired filtration surface area, and varying sludge frame capacities are accommodated. Various pump styles and additional options are also available. Lab and pilot scale size filter presses are offered in a 4" round frame size.

TYPICAL APPLICATIONS

- ▶ Cosmetics & Toiletry Preparations
- ▶ Dyes, Pigments & Inks
- ▶ Enzymes & Gelatins
- ▶ Fine Chemical Purification
- ▶ Fragrances
- ▶ Flavoring Extracts & Syrups
- ▶ Food & Beverage Processing
- ▶ Heavy Metal Reduction
- ▶ Industrial Oils & Coolants
- ▶ Pharmaceutical & Biological Filtration
- ▶ Process Fluid Clarification
- ▶ Odor Removal
- ▶ Waste Water Treatment

<u>FEATURES</u>	→	<u>BENEFITS</u>
◆ Precisely engineered and manufactured with sturdy construction.	→	<ul style="list-style-type: none"> ◇ Withstands high operating temperatures. ◇ Maintains system integrity and minimizes leakage. ◇ USDA approved.
◆ Flexible, modular design.	→	<ul style="list-style-type: none"> ◇ Customizable to meet specific application needs. ◇ Easily retrofitted as application needs change. ◇ Lab and pilot size models for trials and scalability.
◆ Expandable configuration.	→	<ul style="list-style-type: none"> ◇ Add/Remove plate and frames for varying batch sizes. ◇ Accommodates changing process requirements.
◆ Internally ported, gasket free design.	→	<ul style="list-style-type: none"> ◇ Positive frame to filter media seal. ◇ Eliminates gasket inventory and gasket compatibility issues. ◇ Reduces cleanup time and labor. ◇ Minimizes product cross-contamination.
◆ Sludge frame of open design.	→	<ul style="list-style-type: none"> ◇ Easier to operate and handle plates, sludge frames, and media. ◇ Accessibility eases cleaning and sanitizing.
◆ Manufactured in the USA.	→	<ul style="list-style-type: none"> ◇ Reduced lead times and shipping costs. ◇ Expedited delivery.



THE CELLULO® PLATE & FRAME FILTER PRESS VARIATIONS

Dimensions

		17" Frame	25" Frame
A	Outlet - Sanitary Tri-Clamp Connection	1 1/2"	2"
B	Inlet - Sanitary Tri-Clamp Connection	2"	2"
C	Outlet Connection Height	25 1/2"	31 1/4"
D	Inlet Connection Height	39 1/2"	51 1/4"
E	Maximum Width	30 1/2"	41"
F	Maximum Height	70"	83"

Options

1	Optional Operator Control
2	Sanitary Tri-Clamp Piping
3	Optional Pump Arrangement
4	Optional Hydraulic Closure
5	Optional Castors

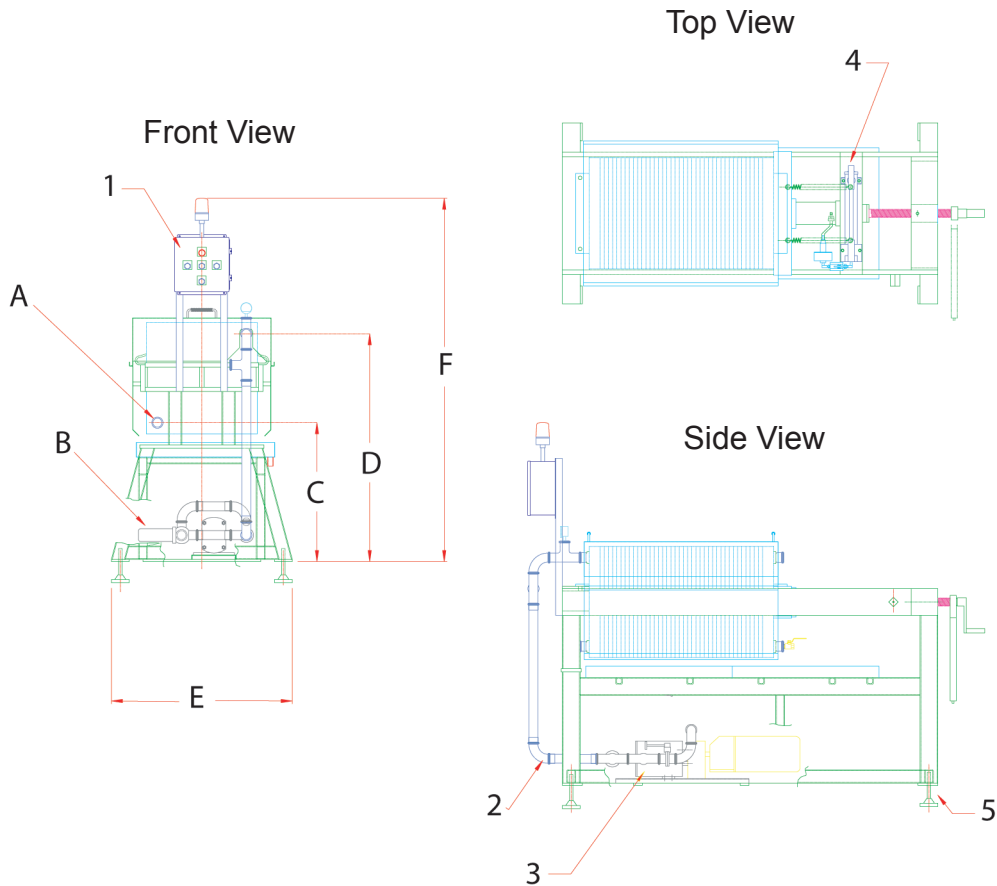

THE CELLULO® PLATE & FRAME PROCESS

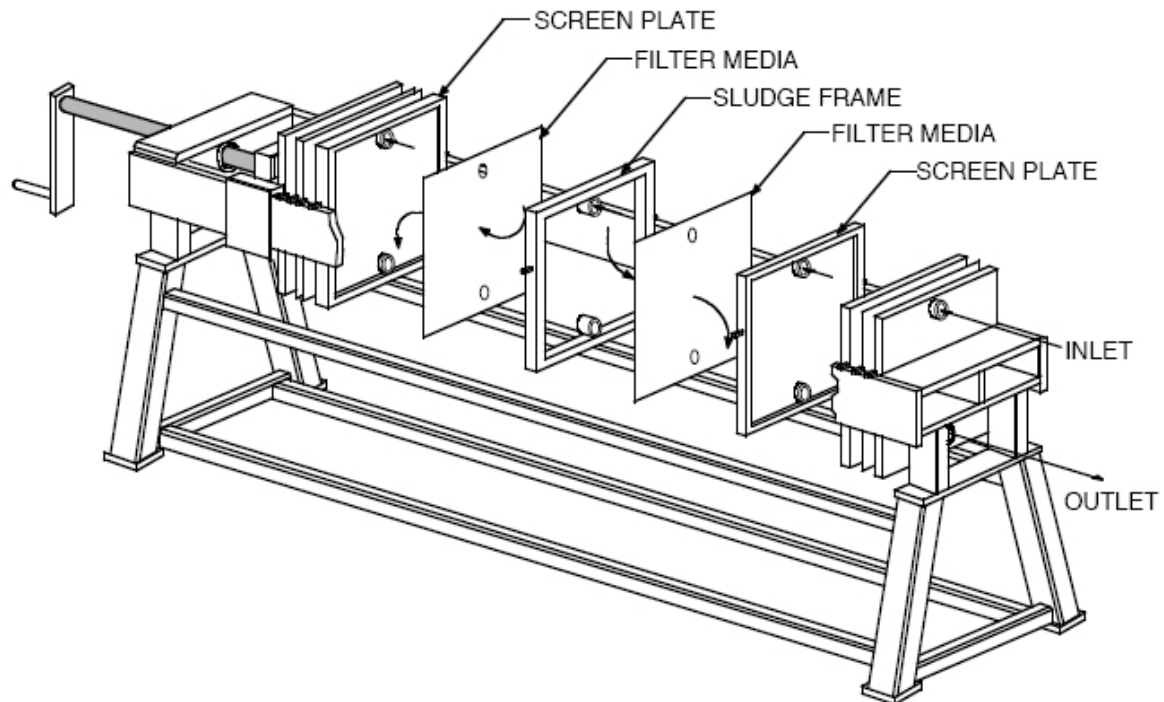

- ◇ Liquid enters through the inlet port initiating the filtration process.
- ◇ The inlet port transports the liquid through every sludge frame filling each one simultaneously.
- ◇ The inlet pressure forces the process fluid through the filter media and into the screen plates located between each sludge frame.
- ◇ The sludge frames capture unwanted solids while the liquid continues to flow into the middle of the screen plate.
- ◇ The liquid then travels into the outlet on the filter press.
- ◇ The inside of the sludge frames catch and hold solid matter creating the filter cake.
- ◇ When the inlet pressure reaches approximately 60 psi the sludge frames are full and the filtration cycle is complete.
- ◇ After the pump is shutdown and the internal static pressure is released the filter press can be opened.
- ◇ The screen plates and sludge frame can then be separated to remove the filter media and filter cake.



AVAILABLE FILTRATION MEDIA

Gusmer Enterprises, Inc. also provides a variety of media for usage within a Plate & Frame Filter Press. All CELLULO® media is manufactured under strict quality control guidelines to ensure uniform and consistent performance.

- ▶ The **Cellupore® 1300SD Series** contains a blend of cellulose fibers suitable for coarse filtration applications in the 1-30 micrometer range. This media exhibits high wet strength, low extractables, and increased throughput and is recommended for applications where diatomaceous earth containing media is unsuitable. Typical applications include: cosmetic, fine chemical, food, beverage, and photographic solution.
- ▶ The **Carbac® 1640 Series** is carbon-impregnated media available in a wide selection of activated carbon sources. Carbac® media is formulated with approximately 67% - 72% carbon by weight retained in a cellulose matrix. This presents a tortuous flow path to ensure intimate contact of the impurities on the surfaces and within the pores of the carbon. Typical applications include: cosmetic, enzymatic, flavor, fragrance, fine chemical, food, beverage, and gelatin.
- ▶ The **Cellupore® 1900SD Series** of gradient density depth filters provides superior throughout capacity. This media exhibits positive charge properties to enhance filtration performance and provides higher wet strength, low extractables, and increased throughput due to advanced manufacturing technologies. Typical applications include: cosmetic, fine chemical, flavor, fragrance, food, beverage, gelatin, and photographic solution.
- ▶ **Cellu-Flo® Fiber Filter Aids** are also available for use in a Plate & Frame Filter Press. These fibers are pure, highly refined alpha cellulose fibers that can be used exclusively or as part of the body feed system to lengthen the filtration cycle time while improving filtration efficiency. Some additional benefits fiber filter aids provide include: prolonged filter septum life, enhanced cake release and discharge, and improved filter cake stability.

